



V1.2

TEN AXIS INERTIAL
16488 SENSOR
Technical Manual

► PRODUCT DESCRIPTION

The 16488 Device Is a Complete Inertial System That Includes a Triaxis Gyroscope, a Triaxis Accelerometer, Triaxis Magnetometer, And Pressure Sensor. Each Inertial Sensor In The 16488 Combines Industry-Leading Technology With Signal Conditioning That Optimizes Dynamic Performance. The Factory Calibration Characterizes Each Sensor For Sensitivity, Bias, Alignment, And Linear Acceleration (Gyroscope Bias). As a Result, Each Sensor Has Its Own Dynamic Compensation Formulas That Provide Accurate Sensor Measurements.

The 16488 Provides a Simple, Cost-Effective Method For Integrating Accurate, Multiaxis Inertial Sensing Into Industrial Systems, Especially When Compared With The Complexity And Investment Associated With Discrete Designs. All Necessary Motion Testing And Calibration Are Part Of The Production Process At The Factory, Greatly Reducing System Integration Time. Tight Orthogonal Alignment Simplifies Inertial Frame Alignment In Navigation Systems. The SPI And Register Structure Provide a Simple Interface For Data Collection And Configuration Control.

The 16488 Uses The Same Footprint And Connector System As The 16375, Which Greatly Simplifies The Upgrade Process. It Comes In a Module That Is Approximately 47 Mm × 44 Mm × 14 Mm And Has a Standard Connector Interface.

► PRODUCT FEATURES

- ★ 0.01% Nonlinearity
- ★ 2000g Shock Survivability
- ★ 6°/Hr In-Run Bias Stability
- ★ Single-Command Self-Test
- ★ Fast Start-Up Time, ~500 Ms
- ★ 0.3°/√Hr Angular Random Walk
- ★ Alarms For Condition Monitoring
- ★ Factory-Calibrated Sensitivity, Bias, And Axial Alignment
- ★ SPI-Compatible Serial Interface
- ★ Digital I/O: Data-Ready Alarm Indicator, External Clock
- ★ Embedded Temperature Sensor
- ★ Optional External Sample Clock Input : Up To 2.4 Khz
- ★ $\pm 0.05^\circ$ Orthogonal Alignment Error
- ★ Power-Down/Sleep Mode For Power Management
- ★ Single-Supply Operation: 3.0 V ~ 3.6 V
- ★ Calibration Temperature Range: -40°C ~ +70°C
- ★ Operating Temp. Range: -40°C ~ +85°C
- ★ Automatic And Manual Bias Correction Controls
- ★ Programmable Operation And Control
- ★ 4 Fir Filter Banks, 120 Configurable Taps
- ★ Triaxial, Digital Accelerometer, ± 18 g
- ★ Digital Pressure Sensor, 300 Mbar To 1100 Mbar
- ★ Triaxial, Digital Magnetometer, ± 2.5 Gauss
- ★ Triaxial, Delta Angle And Delta Velocity Outputse
- ★ Triaxial, Digital Gyroscope, $\pm 450^\circ/\text{Sec}$ Dynamic Rang

► APPLICATION

Platform stabilization and control

Navigation

Personnel tracking

Instrumentation

Robotics

► SPECIFICATION

Parameter	Test Conditions/Comments	Min	Typ	Max	Unit
GYROSCOPES					
Dynamic Range		±450		±480	°/sec
Sensitivity	x_GYRO_OUT and x_GYRO_LOW (32-bit)		3.052 × 10 ⁻⁷		°/sec/LSB
Repeatability ¹	-40°C ≤ T _A ≤ +70°C			±1	%
Sensitivity Temperature Coefficient	-40°C ≤ T _A ≤ +70°C, 1 σ		±35		ppm/°C
Misalignment	Axis-to-axis		±0.05		Degrees
	Axis-to-frame (package)		±1.0		Degrees
Nonlinearity	Best-fit straight line, FS = 450°/sec		0.01		% of FS
Bias Repeatability ^{1,2}	-40°C ≤ T _A ≤ +70°C, 1 σ		±0.2		°/sec
In-Run Bias Stability	1 σ		6.25		°/hr
Angular Random Walk	1 σ		0.3		°/√hr
Bias Temperature Coefficient	-40°C ≤ T _A ≤ +70°C, 1 σ		±0.0025		°/sec/°C
Linear Acceleration Effect on Bias	Any axis, 1 σ (CONFIG[7] = 1)		0.009		°/sec/g
Output Noise	No filtering		0.16		°/sec rms
Rate Noise Density	f = 25 Hz, no filtering		0.0066		°/sec/√Hz rms
3 dB Bandwidth			330		Hz
Sensor Resonant Frequency			18		kHz
ACCELEROMETERS					
Dynamic Range	Each axis	±18			g
Sensitivity	x_ACCL_OUT and x_ACCL_LOW (32-bit)		1.221 × 10 ⁻⁸		g/LSB
Repeatability ¹	-40°C ≤ T _A ≤ +70°C			±0.5	%
Sensitivity Temperature Coefficient	-40°C ≤ T _A ≤ +70°C, 1 σ		±25		ppm/°C
Misalignment	Axis-to-axis		±0.035		Degrees
	Axis-to-frame (package)		±1.0		Degrees
Nonlinearity	Best-fit straight line, ±10 g		0.1		% of FS
	Best-fit straight line, ±18 g		0.5		% of FS
Bias Repeatability ^{1,2}	-40°C ≤ T _A ≤ +70°C, 1 σ		±16		mg
In-Run Bias Stability	1 σ		0.1		mg
Velocity Random Walk	1 σ		0.029		m/sec/√hr
Bias Temperature Coefficient	-40°C ≤ T _A ≤ +85°C		±0.1		mg/°C
Output Noise	No filtering		1.5		mg rms
Noise Density	f = 25 Hz, no filtering		0.067		mg/√Hz rms
3 dB Bandwidth			330		Hz
Sensor Resonant Frequency			5.5		kHz
MAGNETOMETER					
Dynamic Range		±2.5			gauss
Sensitivity			0.1		mgauss/LSB
Initial Sensitivity Tolerance				±2	%
Sensitivity Temperature Coefficient	1 σ		275		ppm/°C
Misalignment	Axis to axis		0.25		Degrees
	Axis to frame (package)		0.5		Degrees
Nonlinearity	Best fit straight line		0.5		% of FS
Initial Bias Error	0 gauss stimulus		±15		mgauss
Bias Temperature Coefficient	-40°C ≤ T _A ≤ +85°C, 1 σ		0.3		mgauss/°C
Output Noise	No filtering		0.45		mgauss
Noise Density	f = 25 Hz, no filtering		0.054		mgauss/√Hz
3 dB Bandwidth			330		Hz
BAROMETER					
Pressure Range		300		1100	mbar
	Extended	10		1200	mbar
Sensitivity	BAROM_OUT and BAROM_LOW (32-bit)		6.1 × 10 ⁻⁷		mbar/LSB
Error with Supply			0.04		%/V
Total Error			4.5		mbar
Relative Error ³	-40°C to +85°C		2.5		mbar
Nonlinearity ⁴	Best fit straight line, FS = 1100 mbar		0.1		% of FS
	-40°C to +85°C		0.2		% of FS
Linear-g Sensitivity	±1 g, 1 σ		0.005		mbar/g
Noise			0.025		mbar rms
TEMPERATURE SENSOR					
Scale Factor	Output = 0x0000 at 25°C (±5°C)		0.00565		°C/LSB
LOGIC INPUTS⁵					
Input High Voltage, V _{HI}		2.0			V
Input Low Voltage, V _{LI}				0.8	V
\overline{CS} Wake-Up Pulse Width		20			μs
Logic 1 Input Current, I _{H1}	V _{HI} = 3.3 V			10	μA
Logic 0 Input Current, I _{L1}	V _{LI} = 0 V				μA
All Pins Except RST				10	μA
\overline{RST} Pin			0.33		mA
Input Capacitance, C _{IN}			10		pF
DIGITAL OUTPUTS					
Output High Voltage, V _{OH}	I _{SOURCE} = 0.5 mA	2.4			V
Output Low Voltage, V _{OL}	I _{SINK} = 2.0 mA			0.4	V
FLASH MEMORY					
Endurance ⁶		100,000			Cycles
Data Retention ⁷	T _J = 85°C	20			Years

16488 SENSOR TEN AXIS INERTIAL

FUNCTIONAL TIMES ⁸	Time until data is available			
Power-On Start-up Time		500		ms
Reset Recovery Time ⁹		500		ms
Sleep Mode Recovery Time		500		μs
Flash Memory Update Time		375		ms
Flash Memory Test Time		50		ms
Automatic Self-Test Time	Using internal clock, 100 SPS	12		ms
CONVERSION RATE		2.46		kSPS
Initial Clock Accuracy		0.02		%
Temperature Coefficient		40		ppm/°C
Sync Input Clock		0.7 ¹⁰	2.4	kHz
POWER SUPPLY, VDD	Operating voltage range	3.0	3.6	V
Power Supply Current ¹¹	Normal mode, VDD = 3.3 V, $\mu \pm \sigma$	254		mA
	Sleep mode, VDD = 3.3 V	12.2		mA
	Power-down mode, VDD = 3.3 V	45		μA
POWER SUPPLY, VDDRTC	Operating voltage range	3.0	3.6	V
Real-Time Clock Supply Current	Normal mode, VDDRTC = 3.3 V	13		μA

► INCONFIGURATION AND FUNCTION DESCRIPTIONS

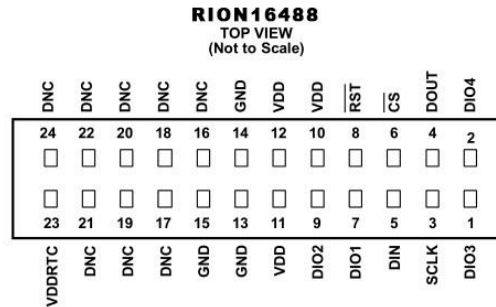

NOTES

1. THIS REPRESENTATION DISPLAYS THE TOP VIEW PINOUT FOR THE MATING SOCKET CONNECTOR.
2. THE ACTUAL CONNECTOR PINS ARE NOT VISIBLE FROM THE TOP VIEW.
3. MATING CONNECTOR: SAMTEC CLM-112-02 OR EQUIVALENT.
4. DNC = DO NOT CONNECT TO THESE PINS.

10277-005

Figure 5. Mating Connector Pin Assignments

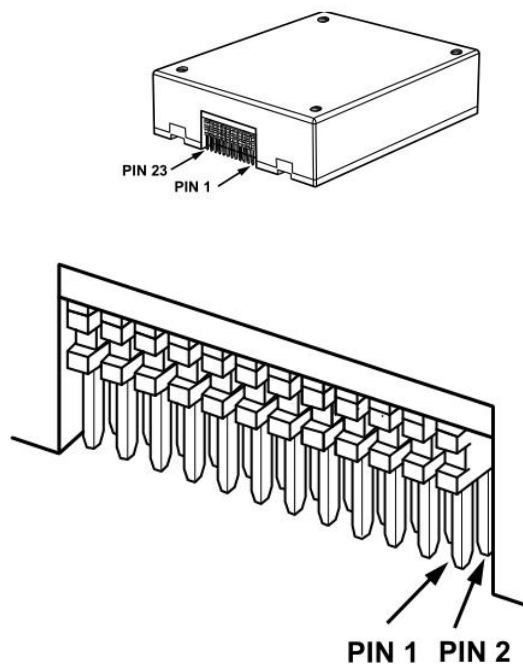

16488 SENSOR TEN AXIS INERTIAL

Pin No.	Mnemonic	Type	Description
1	DIO3	Input/output	Configurable Digital Input/Output.
2	DIO4	Input/output	Configurable Digital Input/Output.
3	SCLK	Input	SPI Serial Clock.
4	DOUT	Output	SPI Data Output. Clocks output on SCLK falling edge.
5	DIN	Input	SPI Data Input. Clocks input on SCLK rising edge.
6	\overline{CS}	Input	SPI Chip Select.
7	DIO1	Input/output	Configurable Digital Input/Output.
8	\overline{RST}	Input	Reset.
9	DIO2	Input/output	Configurable Digital Input/Output.
10, 11, 12	VDD	Supply	Power Supply.
13, 14, 15	GND	Supply	Power Ground.
16 to 22, 24	DNC	Not applicable	Do Not Connect to These Pins.
23	VDDRTC	Supply	Real-Time Clock Power Supply.

► DIMENSION

